

The compact 4x4x4 VF 1.33B loader & backhoe loader has reached the goal to work as a skid loader or as a mini-excavator, but overcoming the limits of the single skid loader and of the single mini-excavator.

In the loader or backhoe version, it represents the only solution which fully responds to Venieri philosophy in compact machinery: an unique product that's superior in terms of productivity, efficiency, flexibility and with low maintenance costs.

The only tool carrier capable of performing in restricted areas or confined operating conditions, in:

EARTHMOVING: excavating, digging, breaking, filling, levelling etc.

CONSTRUCTION: transporting materials, opening trenches, grading, burying, levelling etc.

ROADS AND PIPES: removing road surfaces, spreading aggregate, opening and closing ditches for pipes and cables etc.

PUBLIC WORKS, PARKS AND GARDENS: Rooting, planting trees, clearing snow, gritting, cleaning road surfaces etc.

Agility and quickness, the ability to handle any kind of public works, high transfer speed, exceptionally compact dimensions and an unbeatable turning radius let you work without disturbing the environment around you, and make the VF 1.33B the essential and affordable solution for every kind of public works.



Venieri
1.33B
4-wheel steering
compact loader
& backhoe loader

"Our aim is to offer an unique product that's superior in terms of productivity, efficiency and flexibility with low maintenance costs".



Venieri
1.33B

4-wheel steering
compact loader
& backhoe loader



= UNI EN ISO 9001/2000 =
CERTIFIED COMPANY

The use of the best materials and components available on the market, the adoption of "heavy duty" transmission only, the choice to avoid electronics in addition with a machine assembly carried out by highly-qualified personnel allow us to join our Clients in affirming that Venieri backhoes are quality products which are irreplaceable – except by another Venieri backhoe.



"Our aim is to offer an unique product that's superior in terms of productivity, efficiency and flexibility with low maintenance costs".

VF Venieri s.p.a.

Via Piratello, 106 - 48022 LUGO (RA) ITALY
Tel. +39 0545 904411 Fax +39 0545 30389

SPARE PARTS
Tel. +39 0545 904429 Fax +39 0545 24555

www.vf-venieri.com

Eng



The compact loader & backhoe loader interpreted by Venieri

SIDE-MOUNTED ENGINE

The Venieri VF 1.33B thanks to its side-mounted engine counterweighted at the opposite side grants:

- Better weight distribution between axles
- Real longitudinal and transverse stability
- Total front and rear visibility
- Very compact dimensions
- Side-mounted radiator (with cooling fan) positioned sideways instead of behind the bucket, permitting always an efficient engine cooling .
- Full access to the machine's hydraulic and mechanical components.
- Reduced dimensions of the front frame enabling a greater unloading distance.



4-WHEEL STEERING AND DRIVE

In the VF 1.33B the highest manoeuvrability in any situation is granted by the 4-wheel steering and drive that, together with a balanced ground load exerted by the wheels, allow at the same time full traction, extremely low tyre wearing and optimum operation without damage to surfaces (soil, asphalt, grassland, gravel).



Worldwide, nothing comparable



DIESEL ENGINE

Engine: 4 cylinder, indirect injection, water-cooled, paper dry filter.
Emissioned engine according to the CEE 97/68 - Step 2

Type	Perkins 404 22
Max. power	40kW - 54 HP
Rated rpm	2800
Net Power ISO/TR 14396	38 kW - 51 HP
Net Power EEC/80/1269	38 kW - 51 HP
Displacement	cm ³ 2.800
Bore	mm 84
Stroke	mm 100

ELECTRIC SYSTEM

Battery	12 Volt
Capacity	60 Ah
Alternator rating	480 W
Reverse warning	Standard
Wiring according with	IP 67 - DIN 40050

TRANSMISSION

Hydrostatic transmission with automatic power regulation and closed circuit with variable displacement pump and motor.
Two forward/reverse speeds with single-lever electric control.

	forward	reverse
1 st gear km/h	0÷8	0÷8
2 nd gear km/h	0÷20	0÷20

AXLES

Designed for heavy duties, all wheel-drive.
Automatic self-locking differentials
Planetary final drives in each wheel.
Front axle: steering and oscillating up to a total angle of 15°
Rear axle: steering and fixed to the frame

BRAKES

Service: hydraulic multi-disc working on the transmission shaft.
Parking: roller-lock type on the split outlet hand-operated.

TYRES

Standard.....10.0/75 x 15.3 - 8 pr.

STEERING

Servo-assisted through hydraulic LOAD SENSING steering units.	
Inner tyres turning radius	mm 800
Outer tyres turning radius	mm 2150
Outer bucket turning radius	mm 2700

HYDRAULIC SYSTEM

LOAD SENSING gear pump with priority valve for the steering circuit.
Modular three-element control valve for the loader, modular six-element control valve for the backhoe.
Double acting hydraulic cylinders.
Hydraulic oil cooling radiator.
Full-flow oil filter on the leakage pipe.

Max. flow	lt/1'	44
Loader relief valve pressure	bar	190
Steering relief valve pressure	bar	140
Lift cylinders	mm	90x455

The illustrations on the present folder do not necessarily show the product standard version. Data and dimensions described in this folder are not binding. Venieri reserves the right of carrying out possible changes at any time and without previous notice because of its policy of steady development and improvement of the products.

Bucket cylinder	mm	65x500
Cycle time	sec	8,5

Loader control
Single lever arm-control with 4-position lifting system and with 3-position bucket system.

Backhoe control
Two levers for backhoe-control, "cloche" type.
Two hydraulic-control independent stabilizers, hydraulically operated.
Side translation with four hydraulic locking devices.

SERVICE CAPACITIES

Engine	kg	7
Front differential + Drop box	kg	2,8
Rear differential	kg	2
Planetary gear	kg	0,2
Hydraulic circuit	kg	55
Brake system	kg	0,3
Fuel	lt	47
Water cooling	lt	11

TECHNICAL FEATURES

Loader

Standard bucket capacity	m ³	0,40
Bucket width	mm	1.400
Breakout force	kg	2.560

Backhoe loader

Type	VF	2,75
Standard bucket capacity	lt	45
Standard bucket width	mm	300
Dipper stick max. penetration capacity	kg	1.400
Max breakout force on the bucket tip	kg	2.600
Hydraulic lifting capacity on the bucket pin up	kg	700
Rotation		180°
A - Max. digging depth	mm	2.750
(Telesc./optional)	mm	3.250
B - Standard digging depth	mm	2.600
(Telesc./optional)	mm	3.100

Dimensions and weights

Max. length in transfer (loader)	mm	3.400
Max. length in transfer (backhoe loader)	mm	3.750
Max. width in transfer	mm	1.400
Width across tyres	mm	1.320
Tracks width	mm	1.050
Ground clearance	mm	270
Standard weight in running order (loader)	kg	2.850
Standard weight in running order (backhoe loader)	kg	3.000
Max. weight in running order	kg	3.300

Venieri 1.33B

4-wheel steering compact loader & backhoe loader



THE CABIN

A place where a full-day work becomes possible.

- Easy-to-reach driver's position thanks to reduced height from ground and access without obstacles through a wide door
- Total visibility at 360 degrees
- Mobile rear window operated by dampers not exceeding the machine's profile even when open
- Large front windscreen with ample front and rear side glasses
- Man-sized driver's position
- Fully equipped instrument panel ergonomically positioned
- Excellent protection against external elements and environmental conditions

MAINTENANCE

One of **VF 1.33B** profitability key factor is represented by the machine extremely reduced downtime. Therefore it has been designed to allow routine inspections to be made quickly and easily: just operate a simple catch to open the engine hood and everything's within your reach.

Productivity, efficiency and flexibility with low maintenance costs

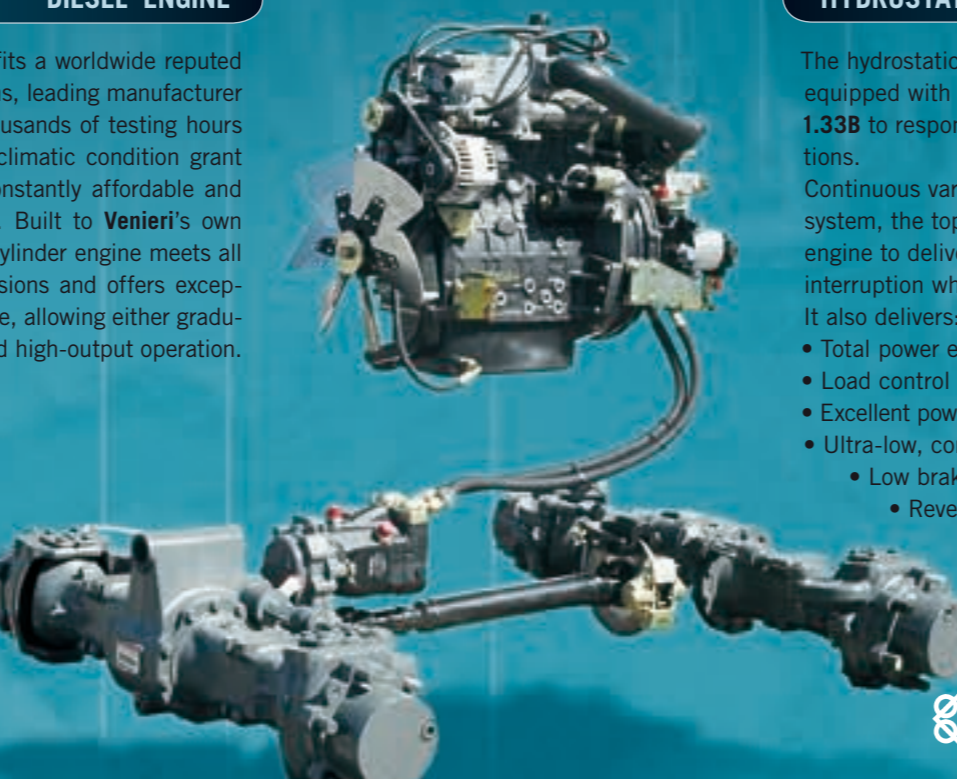

DIESEL ENGINE

The **Venieri VF 1.33B** fits a worldwide reputed engine made by Perkins, leading manufacturer of diesel engines. Thousands of testing hours under every possible climatic condition grant an engine assuring constantly affordable and reliable performances. Built to **Venieri's** own specifications, the 4-cylinder engine meets all requirements on emissions and offers exceptional power and torque, allowing either gradual and high-output operation.

HYDROSTATIC TRANSMISSION

The hydrostatic transmission, joined with twin drive axles both equipped with 40% self-locking differential gears, allow the **VF 1.33B** to respond to all your needs in all possible working conditions.

Continuous variation in transmission ratio linked to an anti-slip system, the top of the "state of the art" technology, allows the engine to deliver every ounce of its power to the wheels without interruption while working to maximum efficiency all the time. It also delivers:

- Total power efficiency even at low rpm
- Load control for more economic fuel consumption
- Excellent power distribution between transmission and hydraulics
- Ultra-low, constant speeds for special equipments
 - Low brake wear thanks to hydrostatic deceleration
 - Reversing without having to stop the machine
 - Comfort during transfers even at maximum speed of 20 km/h

OPTIONAL EQUIPMENT

LOADER

- Mechanical or hydraulic quick coupling
- Mixing bucket
- Multi-purpose bucket (4x1)
- Arm with hydraulic shredder
- Device for ultra low speed
- Lifting forks
- Asphalt/cement planer
- Snow blower
- "V" type or "angle dozer" snow blade
- Angle-tilt dozer blade
- Hand-operated hammer
- Rotating brush
- Trencher

BACKHOE LOADER

- Mechanical quick coupling
- Bucket with mechanical ejector
- Clamshell bucket
- Ditch cleaning bucket
- Backhoe bucket of different widths.
- Extensible dipperstick
- Asphalt/cement hammer
- Hydraulic shredder
- Hydraulic drilling auger

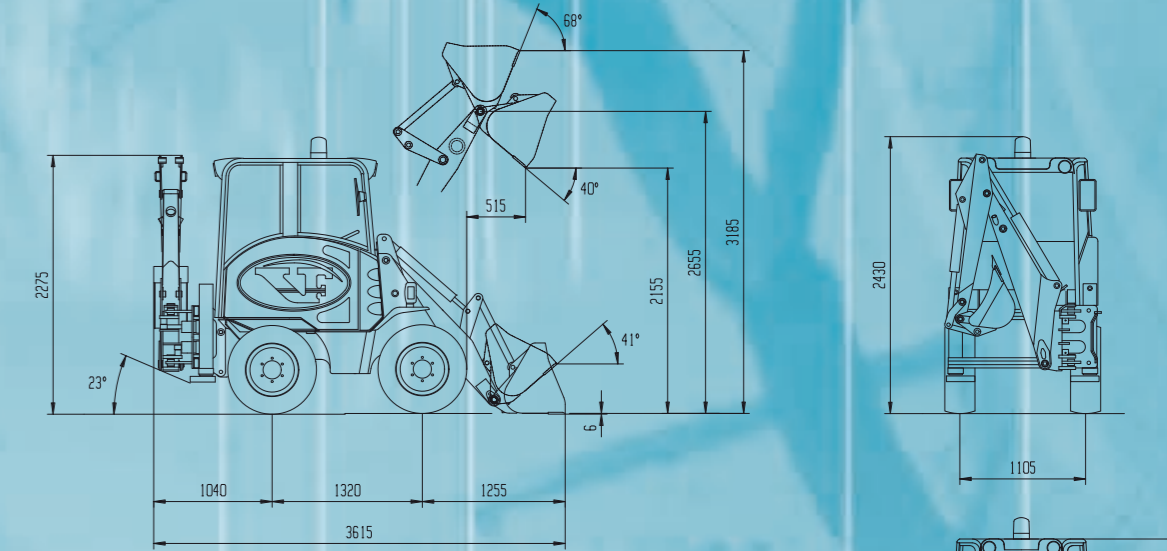

Loading bucket (kg)	
Stating tipping load - Full turn	1.500
Payload (50%)	750

Loading fork (kg) - centre of gravity 500 mm	
Stating tipping load - Full turn	1.200
Payload EN 474-3 (80%)	950
Payload EN 474-3 (60 %)	750
Payload DIN 24094 (50 %)	600

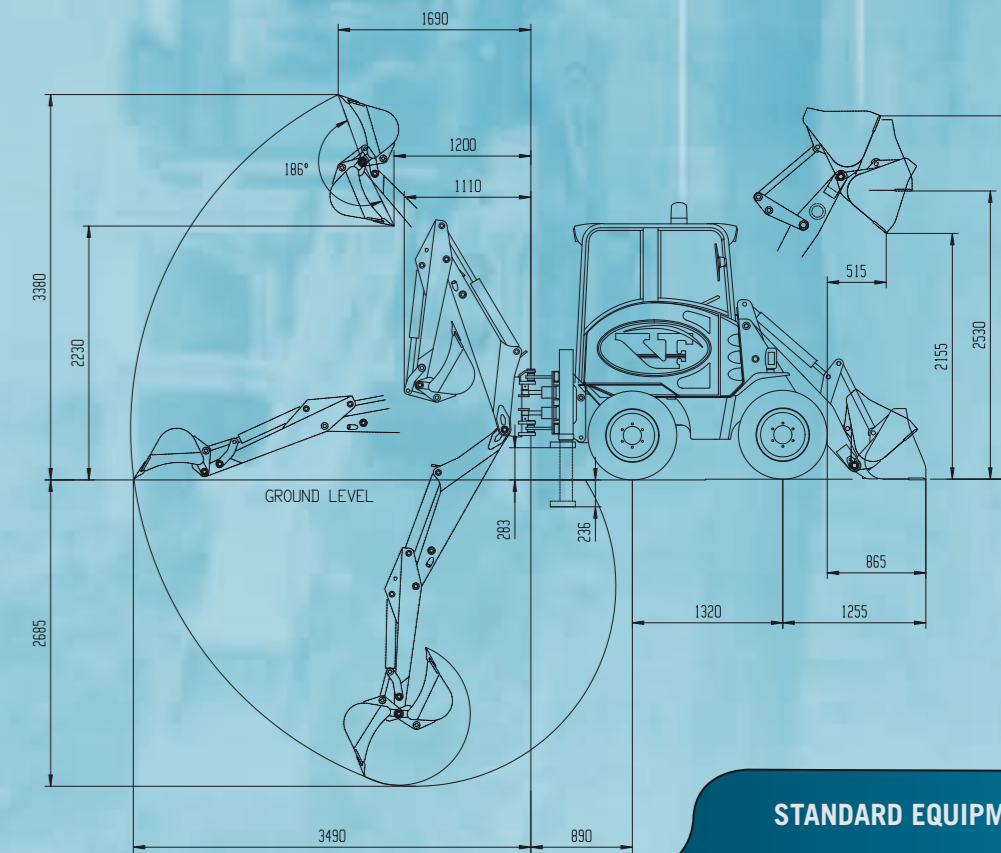

STANDARD EQUIPMENT

- Acoustic reverse warning
- Plug with key for fuel tank
- Front bucket with bolted teeth
- Backhoe bucket
- ROPS/FOPS pressurized cab with heating system with front and rear windscreen wiper and windshield washer.
- Tool box
- Spare parts catalogue
- Safety seat belt
- Limited Slip differential on front and rear axles
- Safety clamp for lifting cylinder
- Safety clamp for backhoe lifting cylinder
- Visual index for bucket position
- Working lights
- Tow hook
- Yellow rotating beacon
- Operation and maintenance manual
- EEC homologation
- Side rearview mirrors
- Complete instrument dashboard

Perkins Rexroth
Bosch Group